

RSB150 RSB150H (HEPA)

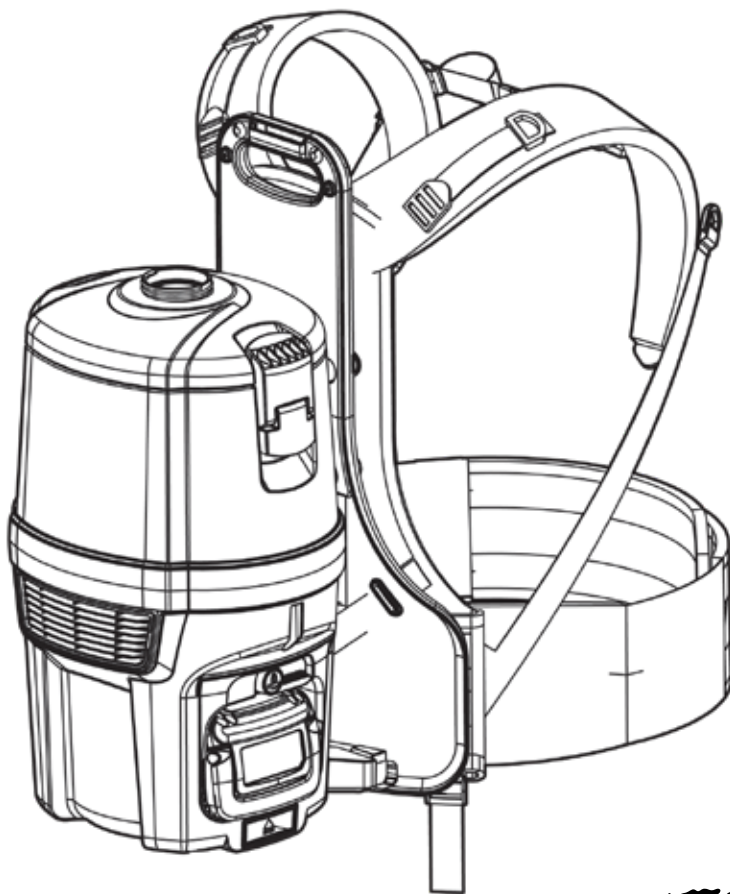

NUMATIC RUCKSACK VACUUM - BATTERY POWERED



Original Instructions

CAUTION,

Read instructions before using the machine.



www.numatic.com

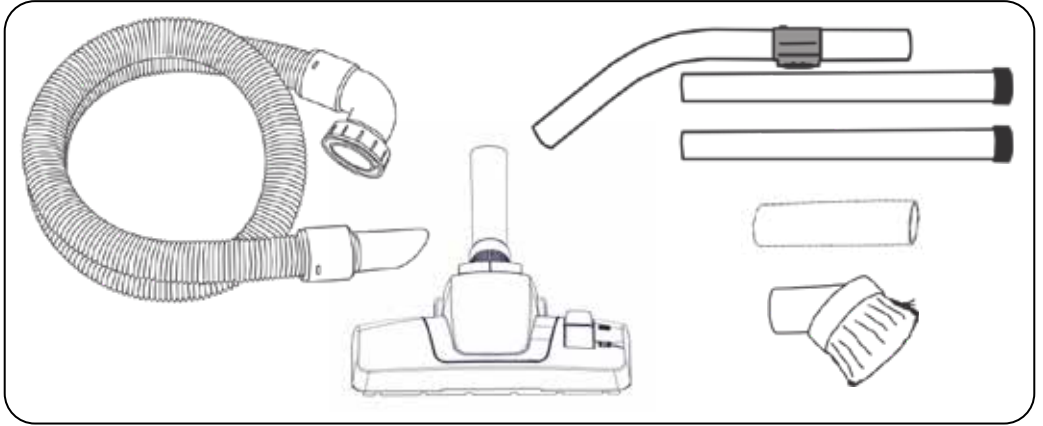

Assembly

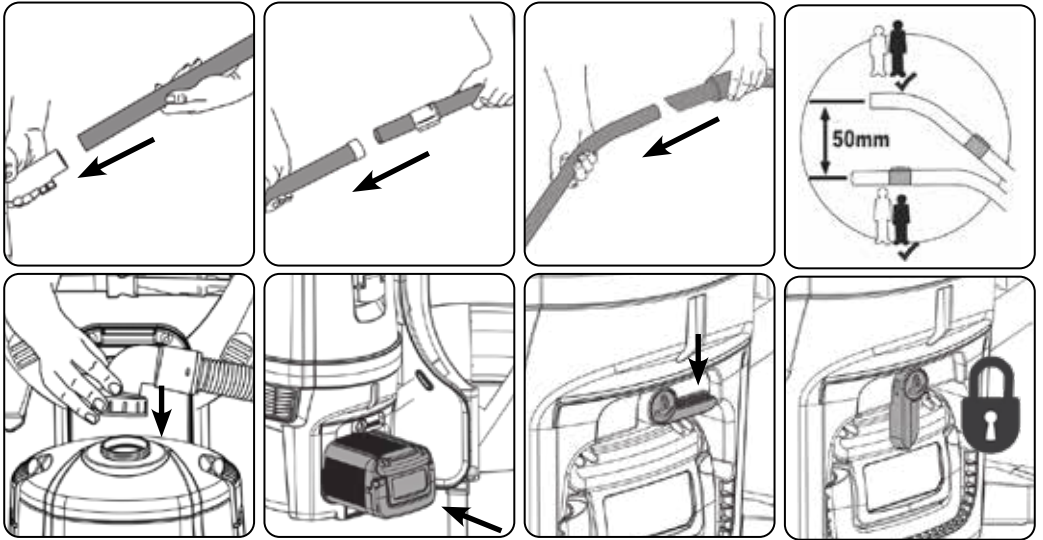

Floortool adjustment

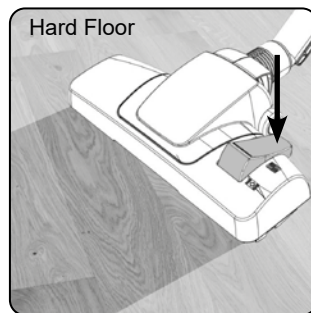
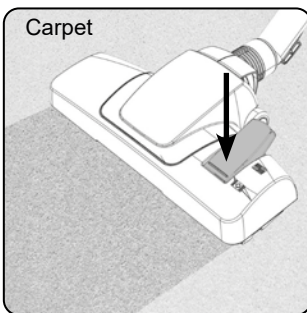

Using the machine

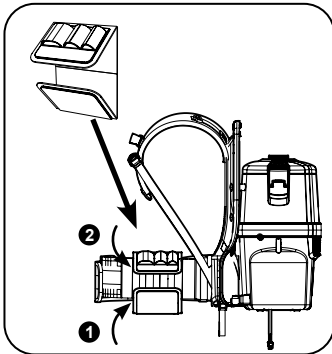

Ensure harness is straight and level.

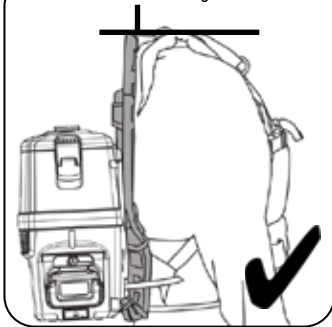

Adjust to fit.

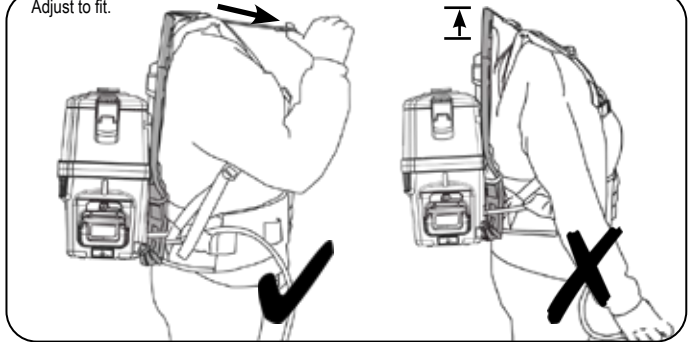

Adjusting harness height

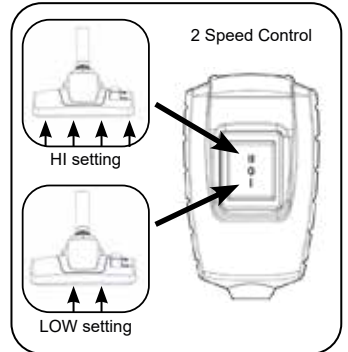
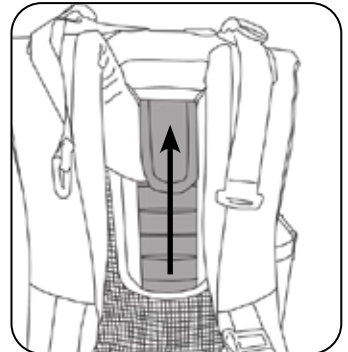
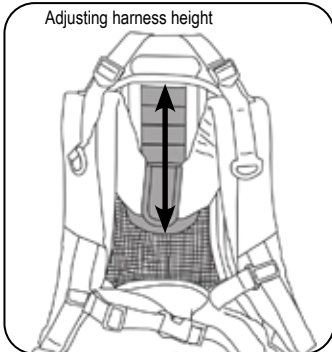

Cleaning your machine

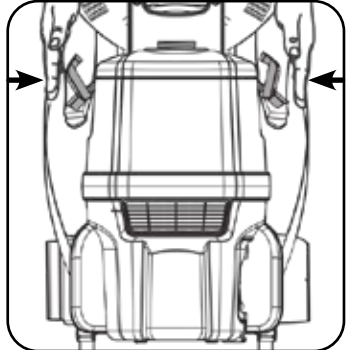
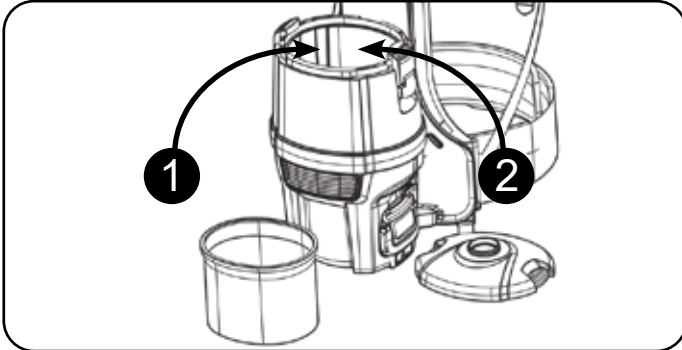
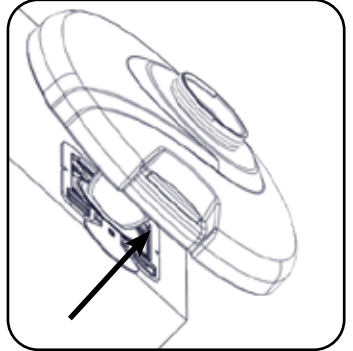
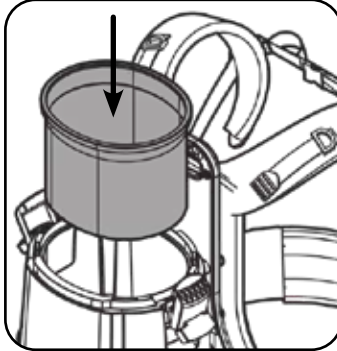
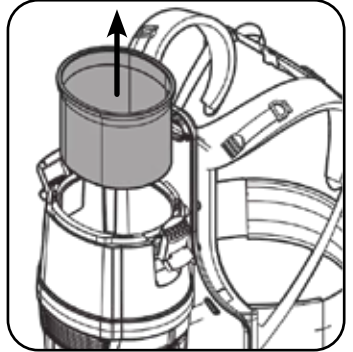
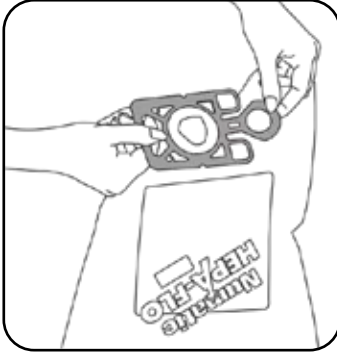
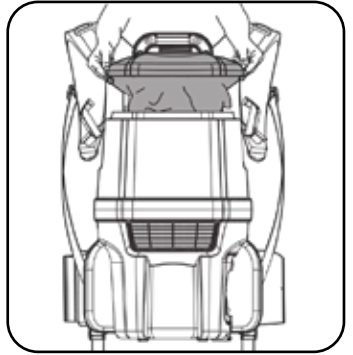
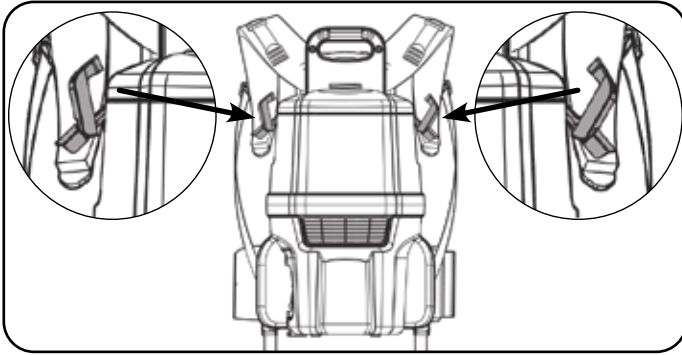

Replacing the Cartridge filter

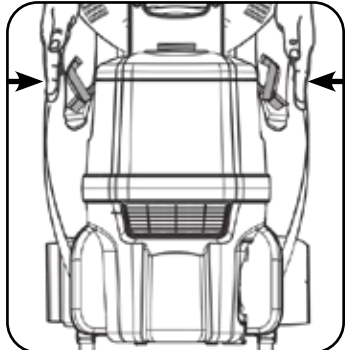
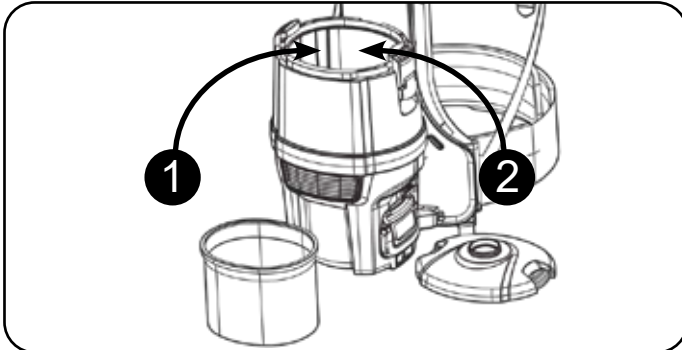
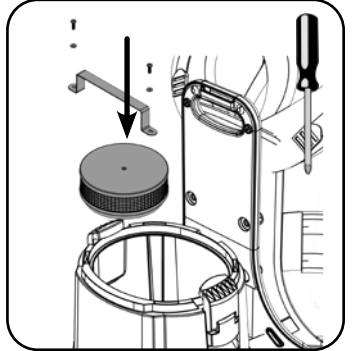
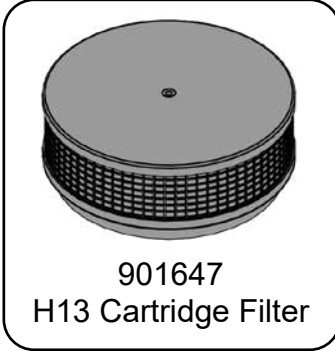
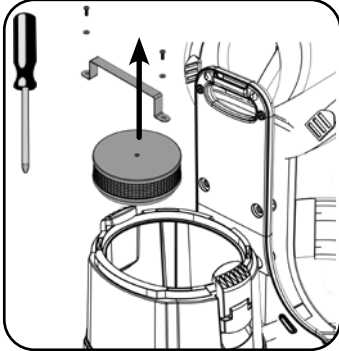
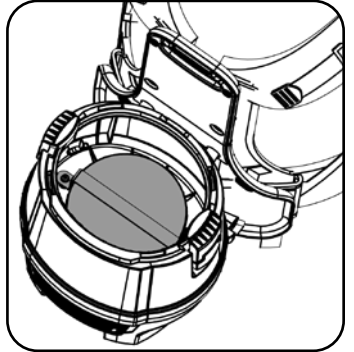
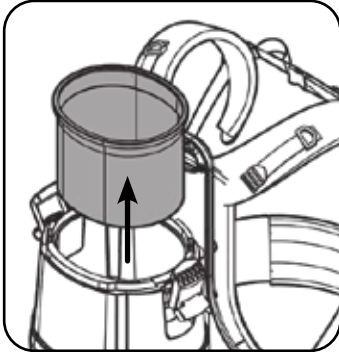
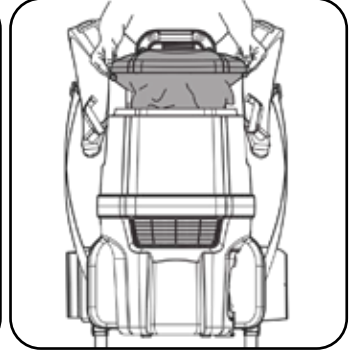
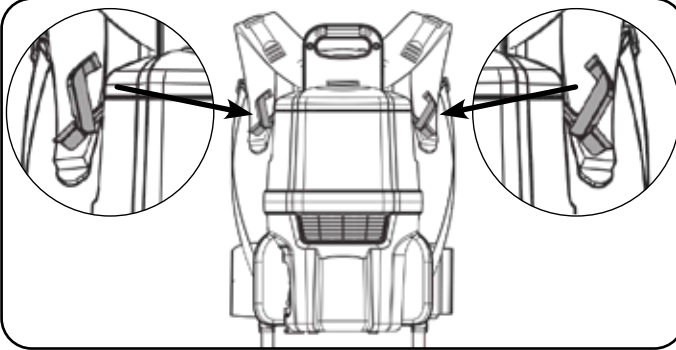

Charging your battery

For information relating to the operation and charging of your battery please refer to the battery and charger original operating instructions

Charging your battery

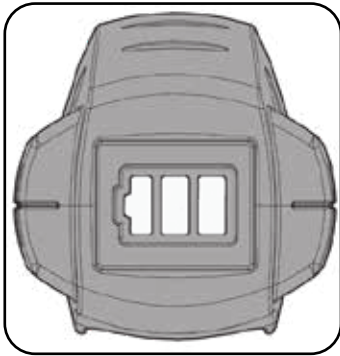

Cleaning time

HI = 49 mins

LO = 83 mins

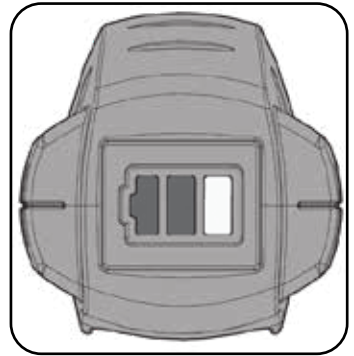

Data

	Voltage	Power Rating	Airflow	Run time	Size
RSB	36V (DC)	350 W / 200 W	HI = 24.0 L/sec LO = 19.9 L/sec	*HI = 49 Mins *LO = 83 Mins	570 mm x 330 mm x 330 mm
RSB (HEPA)			HI = 22.7 L/sec LO = 18.0 L/sec		
	Weight	Dust bag	Capacity	Charge time	
RSB	8.2 kg	NVM-1AH	3.0 Ltr	*1hr to 80% charge – fast charger *2hrs to 100% charge – fast charger *4.5hrs to 100% charge – slow charger	
RSB (HEPA)	8.6 kg		2.0 Ltr		
	High Power Mode			Low Power Mode	
RSB	Sound Pressure (LpA): 63.0dB(A) Uncertainty (KpA): 0.5dB			Sound Pressure (LpA): 62.0dB(A) Uncertainty (KpA): 0.5dB	
RSB (HEPA)	Sound Pressure (LpA): 66.5dB(A) Uncertainty (KpA): 0.5dB			Sound Pressure (LpA): 64.0dB(A) Uncertainty (KpA): 0.5dB	

*Run and Recharge times may vary dependent on ambient temperature.

(GB) About your machine

Rating Label

1	Voltage / Supply
2	Rated input power
3	Weight (ready to work)
4	Company name & address
5	Model
6	Machine yr/wk Serial number
7	CE Mark
8	WEEE Logo
9	Use Lithium Ion Battery Only

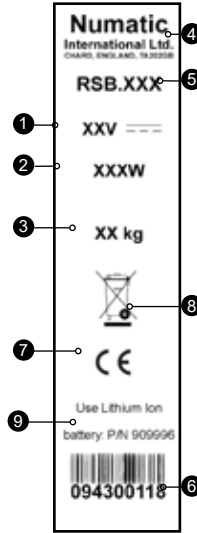

Maintenance

Daily

Keep the machine clean, including hoses and tubes.
Ensure the bag and filter are fitted.
Regularly examine the power cord.
Check dust bag frequently.
Check filters are clean.

Weekly - as daily and:-

Check for any worn or damaged parts and replace immediately.

WEEE (Waste, Electrical and Electronic Equipment)
Vacuum Cleaner Accessories and packaging should be sorted for environmentally-friendly recycling.

Only for EU countries.
Do not dispose of Vacuum Cleaner into household waste.
According to the European Directive 2012/19/EU on waste electrical electronic equipment and its incorporation into national law.
Vacuum cleaners that are no longer suitable for use must be separated, collected and sent for recovery in an environmentally-friendly manner.



PPE (Personal protective equipment) that may be required for certain operations.

Ear Protection	Safety Footwear	Head Protection	Safety Gloves	
				Caution Floor Sign
Eye Protection	Protective Clothing	Dust / Allergens Protection	Hi Viz Jacket	

NOTE: A risk assessment should be conducted to determine which PPE should be worn.

Safety Critical Components

Multi-Regional Charger (100-240V ~ 50/60 Hz) Lithium- Ion Battery 8.1Ah

Failure to rectify the problem or in the event of a breakdown contact your Numatic dealer or the Numatic Technical helpline +44 (0)1460 269268

Information for DRY use vacuum cleaners



ORIGINAL INSTRUCTIONS. READ MANUAL BEFORE USE.



WARNING

Read the instruction manual before using the machine.

Operators shall be adequately instructed on the use of these machines, as with all electrical equipment, care and attention must be exercised at all times during use, you must also make certain that routine and preventative maintenance is carried out periodically to ensure safe operation.

Failure to carry out maintenance as necessary, including the replacement of parts to the correct standard could render this equipment unsafe and the manufacturer can accept no responsibility in this respect.

This machine is for DRY USE only.

You must remove the battery from the machine BEFORE cleaning or maintenance and when replacing parts or converting the machine to another function.

This appliance is intended to be assembled, cleaned and maintained by an adult.

This machine is not suitable for the collection of biological hazards, hazardous or explosive dusts.

Contact your local distributor if you require a machine capable of performing these tasks.

This machine is not intended for use by persons (including children) with reduced physical, sensory or mental capabilities, or lack of experience and knowledge.

Children should be supervised to ensure that they do not play with the appliance.

This machine is not a toy; children shall not play with this machine.



CAUTION

This machine must not be stored outside, or used in wet environments, or to collect wet materials.

The vacuum cleaner should be stored in a dry place and is for indoor use only.

You must ensure that the filtration system fitted to the machine is suitable for the material being collected.

NOTE:

The primary use for this machine is commercial, for example in hotels, schools, hospitals, factories, shops and offices.

This product complies with the requirements of clause 20 of EN/IEC 60335-2-69 Stability and Mechanical Hazards.

This vacuum cleaner is fitted with a thermal protection device.

If the vacuum cleaner has a blockage, remove the battery and inspect the floor tool, tubes and hose for debris.

If the floor tool, tubes and hose are clear, replace the dust bag and clean the filter.

The vacuum cleaner should be inspected after use for damage.

The vacuum cleaner should be stored in a dry place.



DO

- Keep your machine clean including hoses and tubes.
- Change dust bag frequently.
- Keep filters clean.
- Keep diffuser filter (where fitted) clean.
- Use filter bags, they will enhance performance and help keep machine clean.
- Use a Numatic Original filter bag under fine dust conditions.
- Keep hoses and tubes clear.
- Replace any worn or damaged parts immediately.



DON'T

- Use to suck up hot ashes or lighted cigarette ends.
- Use steam cleaners or pressure washers to clean the machine or use in the rain.
- Immerse in water for cleaning.
- Attempt machine maintenance or cleaning unless battery has been removed from the machine.
- Do not use in wet environments or to collect wet materials.
- Under any circumstances place foreign objects including (but not limited to) air fresheners, air freshener capsules or scented beads of any type into the top filter of the machine. Doing so can be dangerous and risk damage to the machine and may invalidate the machine warranty.

Replacement parts

Filter	
910915 / 910945	Tritex filter
901647	H13 Cartridge Filter
HepaFlo dust bags	
604011	NVM-1AH Dust bags (Pack of 10)
Battery	
909996	37 V Battery
Charger	
607846	Standard battery charger dock & mains lead (UK)
Fast charger	
911334	Fast battery charger dock (UK)
912365	Mains charge lead (UK)

Schematic diagram

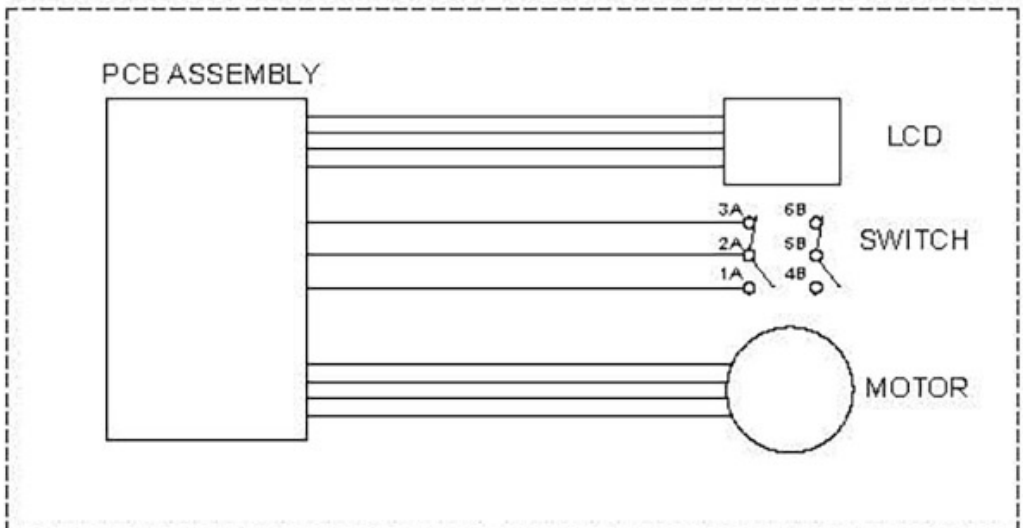

Declaration of conformity

<p>EU, EC, EL, UE, ES: Declaration of Conformity Prohlášení o shodě Konformitátselkiárung Overensstemmelseserklárung Declaración de conformidad Vastavusdeklaratsioon Déclaration de conformité</p>	<p>Дeкларация за съответствие Δήλωση συμμόρφωσης Megfelelőségi nyilatkozat Dichiarazione di conformità Atitikties deklaracija Conformiteitsverklaring Samsvarserklárung Declaração de conformidade</p>	<p>Deklaracja zgodności Declaratie de conformitate Декларация о соответствии Försäkran om överensstämmelse Izjava o skladnosti Vaatimustenmukaisuusvakuutus</p>
<p>Manufacturer: / Výrobce / Hersteller / Fabrikant / Fabricante / Tootja / Fabricant / производитель / Κατασκευαστής / Gyártó / Fabricante / Gamintojas / Fabrikant / Produzent / Fabricante / Producent / Producător / производитель / Tillverkare / Proizvajalca / Valmistaja:</p>	<p>Numatic International Limited Chard Somerset TA20 2GB www.numatic.co.uk</p>	
<p>Product: / Produkt / Produkt / Produkt / Producto, Toode, Produit / Προϊόν / Termék / Prodotto / Produkta / Artikel / Produkt / Produtos / Produkt / Produe / товар / Produkt / Izdelka / Tuote:</p>	<p>RSB</p>	
<p>Description: / Popis / Beschreibung / Beskrivelse / Descripción / Kirjeldus / La description / Описание / Περιγραφή / Leirás / Descrizione / Apibudinimas / Omschrijving / Beskrivelse / Descrição / Opis / Descriere / Описание / Beskrivning / Opis / Kuvaus:</p>	<p>Vacuum Cleaner – Commercial – Dry - Battery</p>	
<p>GB We, Numatic hereby declare under our sole responsibility, that the above-mentioned product(s) is/are in conformity with the following directives and standards. CZ My, Numatic prohlašujeme na svou výlučnou odpovědnost, že výše uvedený výrobek je ve shodě s následujícími směrniciemi a normami. DE Wir, Numatic erklären in alleiniger Verantwortung, dass das oben genannte Produkt den folgenden Richtlinien und Normen entspricht. DK Vi, Numatic erklærer hermed under eget ansvar at ovennævnte produkt(er) er i overensstemmelse med følgende direktiver og standarder. ES Nosotros, Numatic declaramos bajo nuestra única responsabilidad que el producto antes mencionado está en conformidad con las siguientes directivas y normas EE Meie, Numatic käesolevaga kinnitame ja kanname ainuiskulst vastutust, et eespool nimetatud toode on kooskõlas järgmistele direktiivide ja FR Numatic déclare sous notre seule responsabilité que le produit mentionné ci-dessus est conforme aux directives et normes suivantes.</p>	<p>BG Ние, Numatic С настоящото декларираме на своя лична отговорност, че посочените по-горе продуктът е в съответствие със следните директиви и стандарти. GR Εμείς, Numatic δηλώνουμε με αποκλειστική μας ευθύνη, ότι το προαναφερόμενο προϊόν συμμόρφώνεται με τις ακόλουθες οδηγίες και πρότυπα. HU Mi, Numatic kijelentjük, egyedüli felelősséggel, hogy a fent említett termék megfelel az alábbi irányelveknek és szabványoknak IT Noi, Numatic dichiara sotto la propria responsabilità, che il prodotto di cui sopra è conforme alle seguenti direttive e norme. LT Mes, "Numatic pareiškiu vienašališkos atsakomybės, kad pirmiau minėtas produktas atitinka šias direktyvas ir standartus NL We verklaren Numatic hierbij op eigen verantwoordelijkheid, dat het bovengenoemde product voldoet aan de volgende richtlijnen en normen NO Vi, Numatic erklærer herved under eget ansvar, at det ovennevnte produktet er i samsvar med følgende direktiver og standarder</p>	<p>PT Nós, a Numatic declaramos, sob nossa exclusiva responsabilidade, que o produto acima mencionado está em conformidade com as diretrizes e normas a seguir. PL My, Numatic Niniejszym oświadczamy z pełną odpowiedzialnością, że wyżej wymieniony produkt jest zgodny z następującymi dyrektywami i normami. RO Noi, Numatic Prin prezenta declaram pe propria raspundere, ca produsul mai sus mentionat este in conformitate cu urmatoarele standarde si directive. RU Мы, Нилфиск овим изьявляем под пуном одговорностю, да наведеног производ је у складу са следећим директивима и стандардима. SE Vi Numatic förklarar härmed under eget ansvar att ovan nämnda produkt överensstämmer med följande direktiv och normer. SI Mi, Numatic izjavljamo s polno odgovornostjo, da je zgoraj omenjeni izdelek v skladu z naslednjimi smernicami in standardi. FI Me, Numatic täten vakuutamme omalla vastuulla, että edellä mainittu tuote on yhdenmukainen seuraavien direktiivien ja standardien mukaisesti</p>
<p>2006/42/EC</p>	<p>Machinery Directive</p>	<p>EN60335-1:2012 + AC:2014 + A11:2014 + A13:2017 EN60335-2-69:2012 EN62233:2008</p>
<p>2014/30/EU</p>	<p>EMC Directive</p>	<p>EN55014-1:2006 + A1:2009 + A2:2011 EN55014-2:1997 + A1:2001 + A2:2008</p>
<p>2011/65/EU</p>	<p>RoHS Directive</p>	

Authorised Signatory: Mr. Allyn Boyes

Position: Head of Research & Development

Numatic International Limited

Chard,

Signed:



Date: 7th Sep 2020

Somerset, TA20 2GB, UK

Numatic International Warranty

Numatic International Limited warrant to the original purchaser that its products are free of defects in both material or workmanship for the period shown below:-

Homecare and Cleancare Vacuum cleaners.....	2 Years
Rotary Floor Machines.....	2 Years
Twintec Auto Scrubber Dryer.....	1 Year
Vario Ride-On Scrubber Dryer.....	1 Year / 1500 hours
Mopping, Compacts, Combi and Servocare Products.....	1 Year
Individual Accessories and Spare Parts.....	6 Months

Note: This warranty expressly excludes consumable parts such as carbon brushes, floor brushes, mops, batteries etc, that are considered replaceable from time to time during the normal working life of the machine.

Using non Numatic dustbags can be detrimental to both machine performance and life and may invalidate the Warranty.

- A. *The warranty period commences from the date the goods are purchased.*
- B. *All warranty claims must be processed through the Dealer from whom the equipment was purchased. The Dealer will co-operate with the purchaser throughout the warranty claims procedure and will arrange any necessary repairs using genuine Numatic parts.*
- C. *If the original Dealer is no longer able to fulfil his obligations please contact Numatic International Limited with full details of the claim and proof of purchase so that this may be processed without delay.*
- D. *Any warranty claim can only relate to the specific part that is proven to be at fault and for which a replacement will be supplied but cannot be extended to constitute a claim against the complete machine.*
- E. *Numatic International will supply the Dealer with any warranty parts required, subject to the claim being validated, after return of the faulty items in accordance with Numatic International Limited's General Conditions of Sale.*
- F. *Claims will not be accepted if they are the result of fair wear and tear, misuse or abuse of any kind.*
- G. *No replacement will be given unless the appropriate evidence of the validity of the claim has been provided to the satisfaction of Numatic International Limited.*
- H. *Numatic International Limited reserve the right to charge for any unnecessary work carried out as a result of an invalid claim.*
- I. *No variation to this warranty may be made or implied by any member of Numatic International Limited or its Dealers unless such variation is in writing and authorised by the Company*

Numatic

Numatic International Limited. Chard, Somerset, TA20 2GB

Telephone: 01460 68600 Fax: 01460 68458

© Numatic International Limited

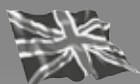

Numatic International Limited.
Chard, Somerset TA20 2GB ENGLAND
Tel: 01460 68600 www.numatic.co.uk

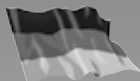

Numatic International GmbH. Fränkische Straße 15–19
D-30455 Hannover, DEUTSCHLAND
Tel: 05 11 98 42 16 0 www.numatic.de

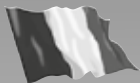

Numatic International SAS. 13 / 17 rue du Valengelier
EAE La Tuilerie – 77500 CHELLES, FRANCE
Tel: 01 64 72 61 61 www.numatic.fr



Numatic International BV
Vennootsweg 15, 2404 CG, Alphen aan den Rijn, NEDERLAND
Tel: 0172 467 999 www.numatic.nl

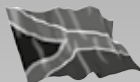

Numatic International (Pty.) Ltd.
16th & Pharmaceutical Roads, Midrand, Gauteng,
SOUTH AFRICA 1685
Tel: 0861 686 284 www.numatic.co.za



Numatic International Schweiz AG.
Sihlbruggstrasse 3A, 6340 Baar. SCHWEIZ
Tel: 0041 (0) 41 76 80 76 - 0 www.numatic.ch



Numatic International ULDA. Rua da Boa Viagem, 177
4470.210 Maia. PORTUGAL
Tel: +351 220 047 700 www.numatic.pt



Numatic International SLU. C/ La Forja, 41, 08840 Viladecans
(Barcelona), Spain
Tel: +34 93 647 22 22 www.numatic.es

Specification subject to change without prior notice
www.numatic.co.uk © Numatic International Limited